

PERFORMANCE DATA SHEET NEMA PREMIUM NR CAN NEMA 12 - 12

Catalogue #: **JMQP-36S**

HP	kW	Voltage	S.F. @ 60Hz	EFF.	P.F.	Frame	Design	L.R. Amps
15	11,19	230/460	1,25	91,0%	0,91	215JM	B	116

60 Hz								Code	F.L. RPM
FLA									
208	230	416	460	480	575	600		G	3510
36,20	34,4	18,10	17,20	16,50	/	/			

50 Hz									
FLA			S.F. @ 50Hz	Efficiency	Power Factor	Code	F.L. RPM		
190	380	415						1,00	89,0%
42,0	21	19,20							

Wgt. Lbs	PH	Duty	Insul. Class	Amb.	Elevation	Temp. Rise° C
162	3	Cont.	F	40°C	1000M (3300 Ft)	59

% Efficiency		% Power Factor		Torque		Winding Resist. Ω	Safe Cold Start (Secs)
Full Load:	91,0%	Full Load:	0,91	Full Load Ft/Lbs	22,4		
3/4 Load:	92,1%	3/4 Load:	0,88	Locked Rotor %	180		
1/2 Load:	91,4%	1/2 Load:	0,80	Break Down %	290		

Rotor Inertia Wk2 Lb-Ft2	Max Load Inertia Wk2 Lb-Ft2	Shaft Material	Frame Material	DE Bracket Type	ODE Bracket Type	Enclosure	NEMA Rating	Lead Wire Size
0,71	75	Standard	Cast Iron	Standard	Standard	TEFC	IP55	12AWG

Ball Bearings		Grease	Mount Type	Orientation	Paint	Sound Pressure @ 3FT	Sound Power
DE	ODE						
6309	6308	Mobil PolyrexEm	Rigid	Horizontal	Green	84	94

Inverter Duty. Motor meets MG1 parts 31.4.4.2	Constant Torque Range	Variable Torque Range	Constant HP RPM
		10:1	20:1

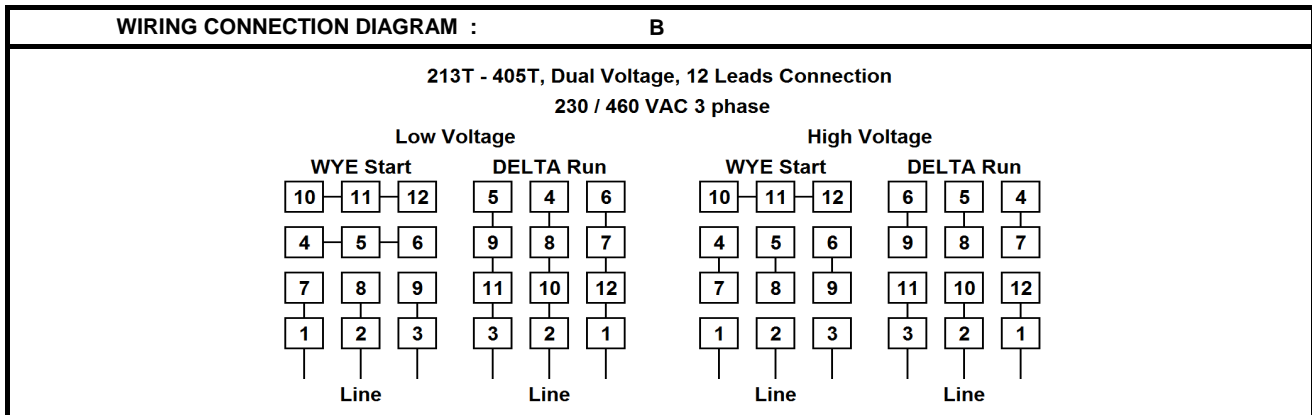

Date: 2020-04-02
 Customer: _____
 Contact: _____
 Submittee: J.C. Lavallée

Catalogue #: **JMQP-36S**

NEMA PREMIUM NR CAN NEMA 12 - 12										
HP	VAC	RPM	Enclosure	Frame	Frequency	Design	Poles	LR Code Letter	Insulation Class	Temp. Rise °C
15	460	3510	TEFC	215JM	60	B	2	G	F	59
	0Hz	6Hz	15Hz	30Hz	45Hz	60Hz	75Hz	90Hz	105Hz	120Hz
Amps	17,2	17,2	17,2	17,2	17,2	17,2	17,2	17,2	17,2	17,2
RPM	0	351	877,5	1755	2632,5	3510	4387,5	5265	6142,5	7020
Torq ft.lb	17,96	22,44	22,44	22,44	22,44	22,44	17,96	14,96	12,83	11,22
Peak Tq ft.lb	27,49	54,99	54,99	54,99	54,99	54,99	43,99	36,66	31,42	27,49
HP	0	1,5	3,8	7,5	11,3	15,0	15,0	15,0	15,0	15,0
	Locked Rotor	Pull-Up	Breakdown	Rated Load	Idle	Duty	S. F.	Ambient	Elevation	dBA @ 1M
Speed (RPM)	0,0	1512	2880	3510	3600	Continuous	1,25	40°C	3300 ft	84
Current (Amps)	116,0	98,6	69,0	17,2	5,0	VFD Rating: Meets MG1 parts 31.4.4.2				
Torque (ft-lbs)	40,4	30,3	65,1	22,4	0,0	C.T.	10:1	V.T.	20:1	

Motor Speed Data

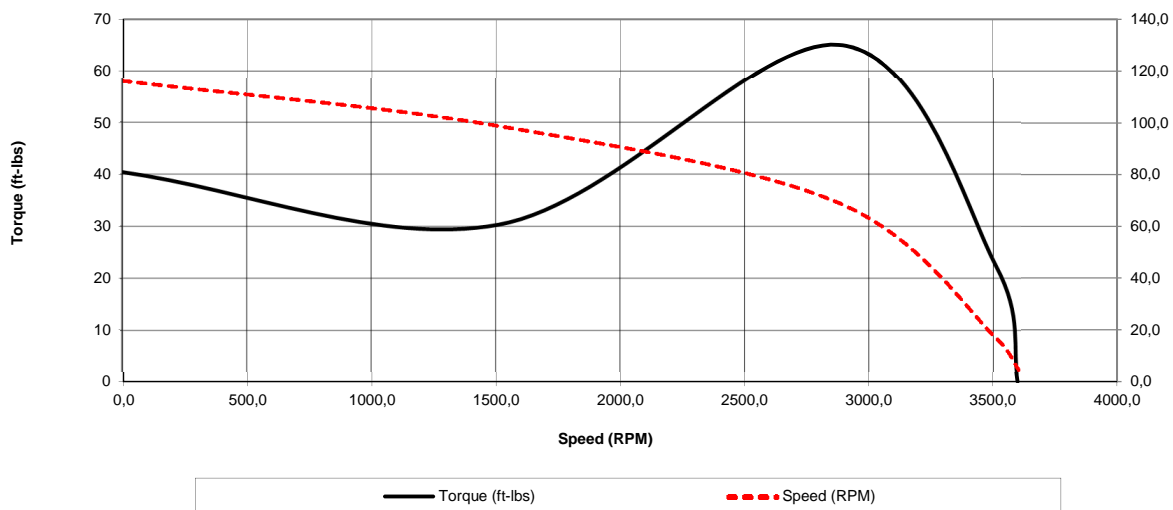

Motor Torque Capability vs RPM

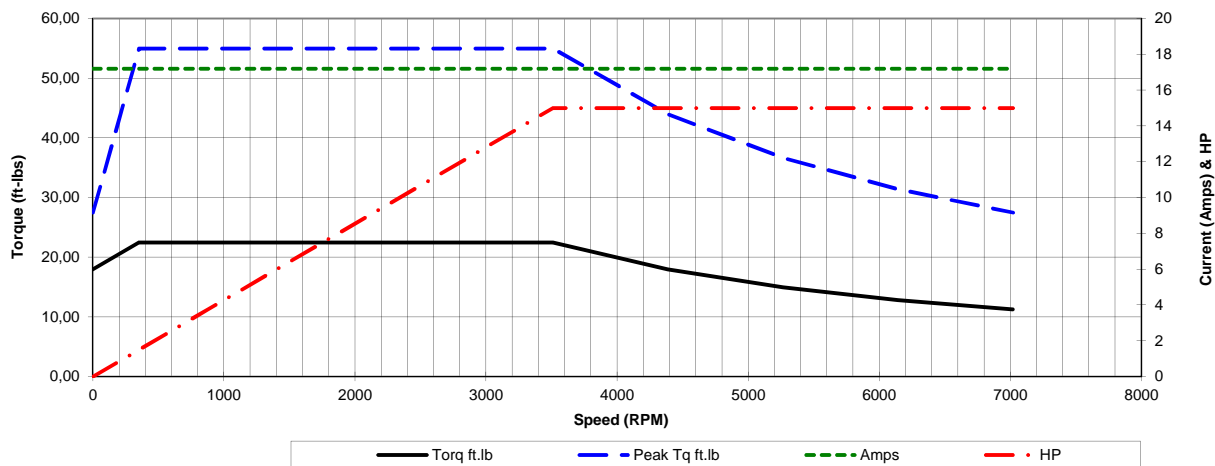



Date: 2020-04-02
 Customer: _____
 Contact: _____
 Submittee: J.C. Lavallée

Catalogue #: **JMQP-36S**

NEMA PREMIUM NR CAN NEMA 12 - 12										
HP	VAC	RPM	Enclosure	Frame	Frequency	Design	Poles	LR Code Letter	Insulation Class	Temp. Rise °C
15	460	3510	TEFC	215JM	60	B	2	G	F	59
Load %	0%	25%	50%	75%	100%	125%	150%			
Amps	5,00	6,55	9,60	13,00	17,20	21,32	25,44			
Torq ft/lbs	0	5,40	10,84	16,30	21,83	27,36	32,97			
RPM	0	3577,5	3555	3532,5	3510	3487,5	3465			
Eff	0	86,46	91,40	92,10	91,00	91,00	91,00			
PF	0	62	80	88	91	90,5	91			
	Locked Rotor	Pull-Up	Breakdown	Rated Load	Idle	Duty	S. F.	Ambient	Elevation	dBA @ 1M
Speed (RPM)	0	1512	2880	3510	3600	Continuous	1,25	40°C	3300 ft	84
Current (Amps)	116	98,6	69,0	17,2	5	VFD Rating: Meets MG1 parts 31.4.4.2				
Torque (ft-lbs)	40,40	30,30	65,09	22,44	0,0	C.T.	10:1	V.T.	20:1	

